

- English -

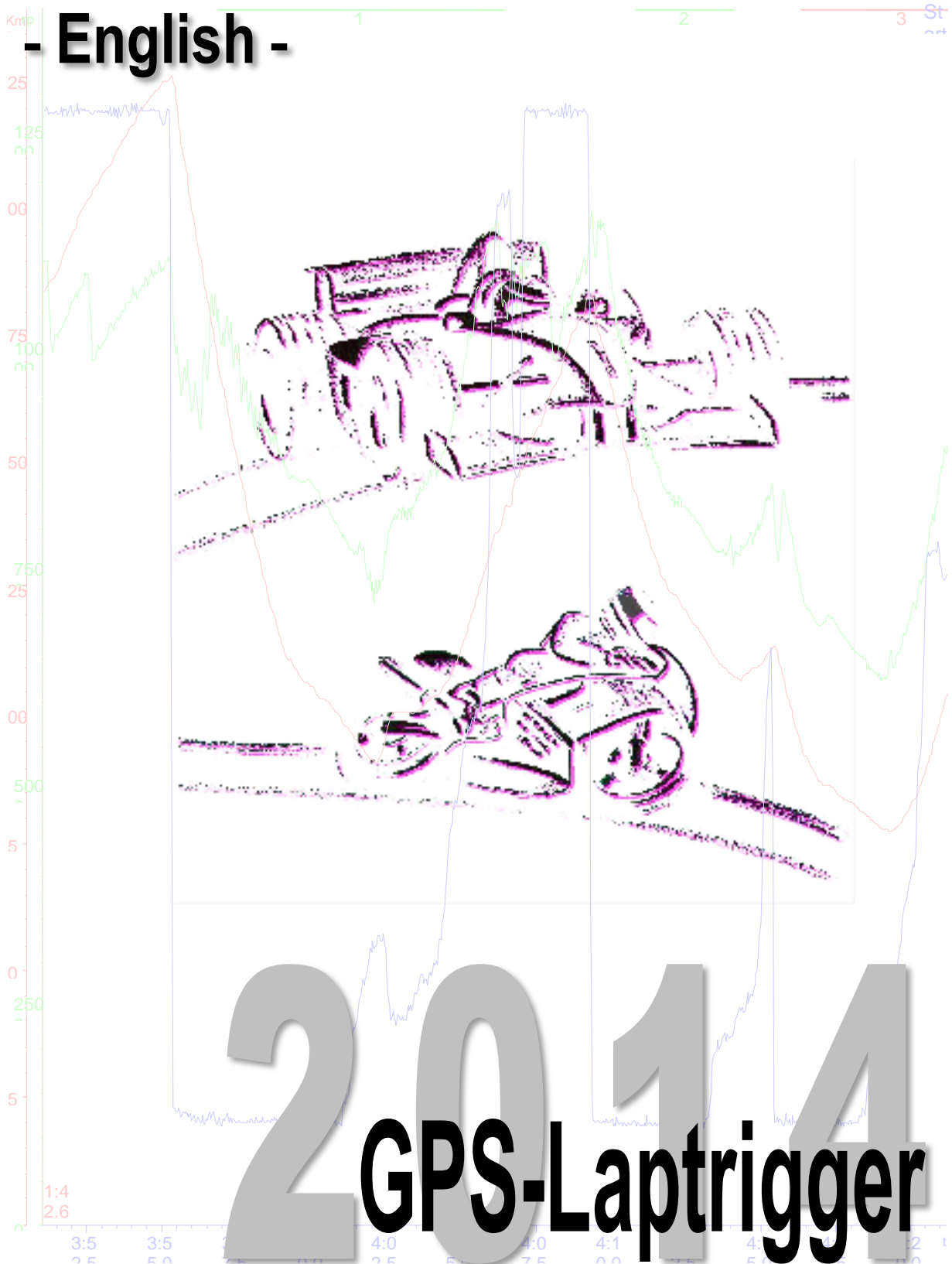

Content

1	INTRODUCTION	3
2	CONNECTING THE LAPTRIGGER	3
3	DEFINING A GPS-LAPTRIGGER-POSITION	3
4	BLINK CODES	4
5	APPENDIX – PREDEFINED TRACKS - 18.06.2014	4

Symbols used in the text



These paragraphs contain tips and practical advice for working with the 2D system



In the paragraphs highlighted with this symbol, you will find additional information and it is very important that you follow the instructions given.



Documentation reference

- A user manual reference number is provided so the user can seek further assistance

1 Introduction

The GPS-Laptrigger is used to generate lap trigger signals via GPS. You can use the predefined start lines of more than 300 race tracks or create your own start line position.

2 Connecting the Laptrigger

The following table shows the connector layout of the GPS-Laptrigger. Pin4 has a combined input/output function. The input function is used for manually defining lap positions. The output function is used for sending the lap-trigger signal.

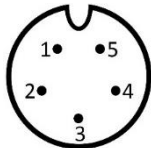
	Pin	Name	Description	Wire color
	1		Do not use!	
	2		Do not use!	
	3	GND	Ground	black
	4	Button/LAP	Push-button in/LAP out	yellow
Binder 712M, 5 pin	5	Vext	Power in (8 V – 18 V)	red

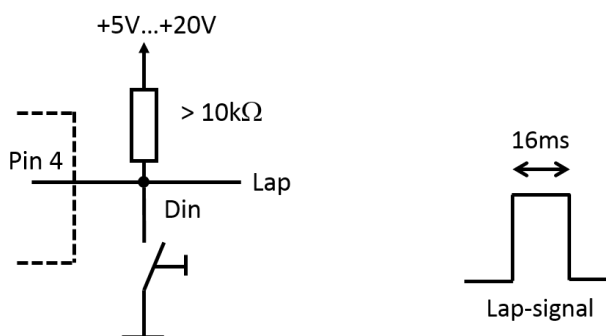

3 Defining a GPS-Laptrigger-Position

There are two ways of input of the GPS coordinates for defining a lap trigger position:

- Automatic: the GPS-Laptrigger searches for matching start line coordinates in its table of predefined race tracks.
- Manual: you can define your own start lines by pushing the button.

As soon as the GPS Laptrigger has found the satellite's signal, it checks if the last used trigger coordinates are valid for the actual position (within a radius of 5 km). If the position is valid, it will be used to create a lap trigger. Otherwise the module searches if there is a matching start line stored in its GPS coordinates table. Have a look at the appendix (section 5) for the race track start lines which are stored in this table.

If there is no matching start line stored or you want to use another position you can manually define a position. To define a position you push the button (refer to section 2) while driving/riding (speed > 5 km/h) – for longer than 0.5 s. The module will then use the actual position of the vehicle (at the start of pushing) as a trigger position.



Manually defined lap trigger positions will not be stored in the table!

You receive the trigger signal for further use on "LAP". Refer to section 2.

To delete the actual used lap trigger position you push the button while the vehicle does not move (speed < 5 km/h). Then the GPS Laptrigger will search again for matching start lines in its table of predefined race tracks.

4 Blink codes

There are three different blink codes implemented:

- 1) If there is no valid GPS signal the blink frequency is 1 Hz
- 2) If the GPS signal is valid the blink frequency is 5 Hz
- 3) If the GPS signal and the trigger coordinates are valid the blink frequency is 12 Hz

5 Appendix – predefined tracks - 18.06.2014

Abbeville	Buddh International Circuit	Fort Devens
Achna Speedway	Bukernieki	Franciacorta
Adelaide	Buttonwillow Raceway	Fuente Alamo
Adria	Cadwell Park	FujiSpeedWay
Ahvenisto	Calabogie	Gateway International
Aiginio	Calafat	Gellerasen Circuit
Aintree	Calder	Gingerman Raceway
Alastaro	California Speedway	Goodwood
Albacete	Campo Grande	Gotland Ring
Albert Park	Cape Town	Grattan
Alcarrás	Carolina Motorsport Park	Grobnik
Ales	Cartagena	Guadix
Almeria	Cascavel	Guapore
Anglesey	Castelloli	Hampton Downs
Anhembi - Sao Paulo	Castle Combe	Hastings Motorsport Park
Anneau du Rhin	Catalunya	Hawai Raceway
Ansan	Charlotte	Heartland Park of Topeka
Arctic Circle Raceway	Chayka	High Plains Raceway
Ascari	Chelsea Handling Track	Hockenheim
Aschheim	Chennai	Homebush
Assen	Chenviers	Homestead
Atlanta Motor Speedway	Chicago	Honjo
Autodromo da Salta	Chicagoland	Hungaroring
Autodromo Goianina	Chuckwalla Valley Raceway	Imola
Autodromo Hermanos Rodrigues	Circuit of the Americas	Inde Motorsports Ranch
Autopolis	Croft	Indianapolis
Bahrain	Croix-en-Ternois	Infineon Raceway
Barbagallo	Curborough	Interlagos
Barber Motorsports Park	Curitiba	Istanbul Park
Baskerville	Darlington Speedway	Jacarepagua
Bathurst	Darwin	Jarama
Bay Meadows	Daytona	Jennings
Beave Run Motorsports Complex	Dijon	Jerez
Bedford Autodrome	Donington Park	Johor
Belle Isle	Dover	Jyllandsring
Bilster Berg	Dreux	Kansas Speedway
Blackhawk Farms	Dubai	Kartodromo Fatima
Blyton Park	Dunsfold	Katar- Losail
Bombarral	East London	Kemora
Botniaring	Eastern Creek	Kentucky Speedway
Braga	Ebisu South	Kinnekulle
Brainerd	Elvington	KIP-Palmela
Brands Hatch	Enna Pergusa	Knockhill
Brasilia	Estoril	Knutstorp
Bresse	Eurospeedway Lausitzring	Korea Intertional Circuit
Bristol	Eusebio	Korfez
Brno	Fay de Bretagne	Kyalami
Broadford	Fiorano	LaFerteGaucher
Bruntingthorpe	Folembay	Laguna Seca

Lakeside Queensland	New Jersey Lightning	Sendai Highland
Las Vegas Motor Speedway	New Jersey Thunderbolt	Sentul
Ledenon	Nikko	Sepang
LeMans	Nogaro	Serres
Lime Rock	Nola Motorsports Park	Shanghai
Ljungbyhed Park	Norisring	Siena
Llandow	Nürburgring	Silverstone
Loheac	Okayama	Slovakia Ring
Lonato	Oran Park	Snetterton
Londrina	Oschersleben	Spa Francorchamps
Loudon	Oulton Park	Spa Nishiura Motor Park
Lydden	Padborg Park	Spring Mountain
Magione	Palm Beach	St Petersburg Street Circuit
Magny Cours	Pannoniarig	Sturup
Mallala	Park Algar	Sugo
Mallorca-Rennarena	Pau Arnos	Summit Point Motorsports Park
Mallory Park	Paul Ricard	Surfers Paradise
Manfeild	Paw	Sviestad
Mantorp	Penbry International	Symmons Plains
Martinsville Speedway	Phillip Island	Talladega Superspeedway
Mas du Clos	Pinarbasi	Taruma
Maze	Pittsburgh	Taupo
Megara	Pocono Raceway	Teretonga
Memphis	Pomposa	Texas Motor Speedway
Mendig	Port Elizabeth	Three Sisters
Miachkovo	Portland	Thruyton
Michelin Laurens Proving Grounds	Poznan	Thunderhill Raceway Park
Mid America	Prestwold Hall	Timaru
Mid Ohio	Pukekohe	Tocancipa
Midvaal	Pukekohe Park Raceway	Tokachi
Miller Motorsports Park	Putnam Park	Track
Milwaukee	Queensland	Troronto Motorsports Park
Misano	Ramenskoe	Tsukuba
Mittsverigebanan	Red Bull Ring	Valencia
Modena	Reno Fernley	Valerbanen
Mont Tremblant	Riberao Preto	Valkenswaard
Montebianco	Rijeka	Vallelunga
Montreal	Ring Djursland	Varano
Monza	Rioveggio	Velo Citta - Mogi Guacu
Morgan Park	Road Atlanta	Velopark
Mornay	Roberto Muras Circuit	Virginia International Raceway
Moroso	Rockingham	Wakefield Park
Mosport	Ruapuna	Waneroo
Most	Rudskogen	Waterford Hills
Motegi	Sachsenring	Watkins Glen
Motopark	Saellandsringen	Welkom
Motorland Aragon	Salzburg	Wesbank Raceway
Motorland Suzuka	Samara-Ring	Willow Springs
Mugello	San Luis Potosi	Winton
Myrtle Beach	Sandia	Yas Marina
Nakhonchaisri	Sandown	Zandvoort
Nardo	Santa Cruz do Sul	Zolder
Nashville	Sauga Circuit Auduring	Zuhai
Navarra	Schleizer Dreieck	Zwartkops Raceway
Nazareth	Sebring	
Nelson Ledges	Seinajoki	