

SA-MAPxxyy-000

Dual channel magnetic angle position sensor

Function

- Dual channel magnetic angle position sensor, including 2 amplifiers
- Measures rotation angle / angle positions with very high resolution (e.g. steering position)

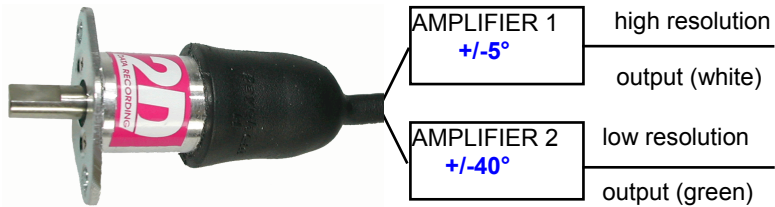

Features

- High resolution
- Wide linear range
- Low weight and small housing
- Long operation life
ball bearings: $>100 \times 10^6$ cycles

Options

- Sensor outputs available from ± 5 to ± 40 , in 5° steps

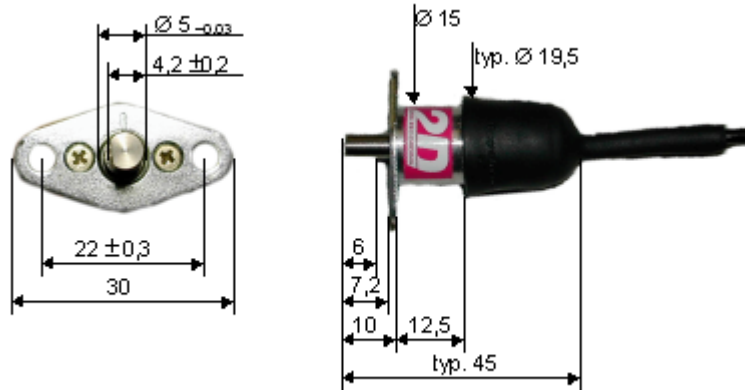

Technical specifications

Electrical characteristics

| | |
|-----------------------------------|----------------|
| Voltage supply..... | 5 V |
| Output voltage..... | 0 - 5 V |
| Two output ranges with one sensor | |
| ➤ high resolution range 1..... | $\pm 5^\circ$ |
| ➤ low resolution range 2..... | $\pm 40^\circ$ |
| Range of linearity (maximum)..... | $\pm 40^\circ$ |

Mechanical characteristics

| | |
|----------------------------|------------------------------|
| Dimensions (over all)..... | $\varnothing 5 \times 62$ mm |
| Mounting rod..... | $\varnothing 5$ mm |
| Weight..... | 12 g |
| Cable | |
| type..... | Raychem, EPD, Y-cable |
| wire cross-section..... | 3 x AWG 26 |
| Length..... | 1200 mm |

Calibration

Use the formulas on 2nd page to calculate the physical values

Connector

Standard..... Binder 719, 5PM
 Optional..... Deutsch ASC605-06PN, 6PM

Standard connector: SA-MAPxxyy-000
 Optional connector: SA-MAPxxyy-001

xx=put in the range of the sensor (=amplifier 1)

yy=put in the range of the sensor (=amplifier 2)

Environmental data

| | |
|------------------------------|---------------------------------|
| Ambient operating range..... | -25 to +80 °C |
| Operation life..... | $> 100 \times 10^6$ full cycles |
| Sealing class..... | IP 65 |

Vibration resistance

| | |
|--------------------------|--------|
| Vibration tested at..... | 10 G |
| | @50 Hz |

Ordering information

Art.No.:..... SA-MAPxxyy-000

SA-MAP xy -000

Dual channel magnetic angle position sensor

Sensor range

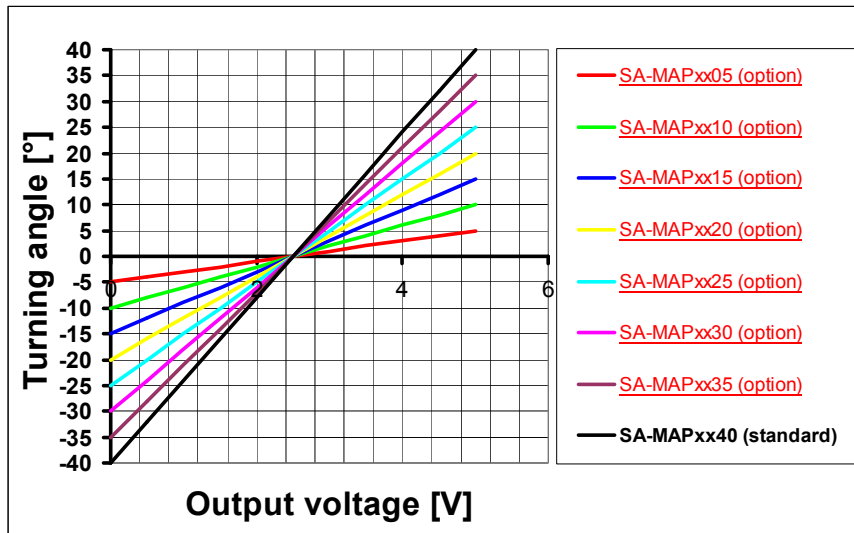

Remark

xx = high resolution range 1 ($\pm 5^\circ$ or all options)

yy = low resolution range 2 with possible options: ± 5 to ± 40 , in 5° steps

Formulas

| SA-MAP xy -000 | | Multiplier | | | | | | | | Offset | | |
|------------------|-------------------|--------------------|------------|------------|------------|------------|------------|------------|------------|--------|--------|------|
| 12 Bit A/D | Turning angle [°] | $= 2 * yy / 4095$ | | | | | | | | * | Digits | - yy |
| 16 Bit A/D | Turning angle [°] | $= 2 * yy / 65535$ | | | | | | | | * | Digits | - yy |
| Voltage* | Turning angle [°] | 2 | 4 | 6 | 8 | 10 | 12 | 14 | 16 | * | Volt | - yy |
| | | SA-MAP0505 | SA-MAP0510 | SA-MAP0515 | SA-MAP0520 | SA-MAP0525 | SA-MAP0530 | SA-MAP0535 | SA-MAP0540 | | | |

= Available options (on customer request)

Replace the **yy** with the turning angle of your sensor: Possible values are 5° , 10° , 15° , 20° , 25° , 30° , 35° and 40°

Connector layout

Connector type Deutsch (standard)

| Pin | *Connector1 | Color | Pin | *Connector2 | Color |
|-----|-------------|-------|-----|-------------|-------|
| 1 | GND | black | 1 | GND | black |
| 2 | +5V | red | 2 | +5V | red |
| 3 | - | - | 3 | - | - |
| 4 | - | - | 4 | - | - |
| 5 | Signal | white | 5 | Signal | green |

Connector types

Connector at sensor

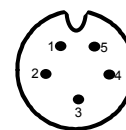

Binder 719, 5 PM - front side - Binder 719, 5 PF

Mating plug

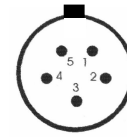

Connector type Deutsch (optional)

| Pin | *Connector1 | Color | Pin | *Connector2 | Color |
|-----|-------------|-------|-----|-------------|-------|
| 1 | GND | black | 1 | GND | black |
| 2 | +5V | red | 2 | +5V | red |
| 3 | - | - | 3 | - | - |
| 4 | - | - | 4 | - | - |
| 5 | Signal | white | 5 | Signal | green |
| 6 | - | - | 6 | - | - |

Connector at sensor

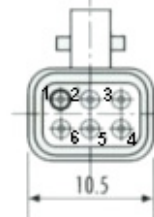

Deutsch ASC605-06PN 6PM (front side)



* connector1 = high resolution range
 * connector2 = low resolution range

The specifications on this document are subject to change at 2D decision. 2D assumes no responsibility for any claims or damages arising out of the use of this document, or from the use of modules based on this document, including but not limited to claims or damages based on infringement of patents, copyrights or other intellectual property rights.

2D Debus & Diebold Meßsysteme GmbH
<http://www.2D-datarecording.com>
<http://www.2D-Kit-System.com>
mail@2D-datarecording.com